

SPINNER

TC300

Precise Universal Lathe



Mechanical Engineering
Made in Europe

www.spinner.eu.com
sales@spinner.eu.com

Machine Highlights

Small distance between operator and chuck

Available with or without driven tool and Y axis

Compact dimensions for low space requirement

Ideal for Hard Turning

Latest control system: Siemens 840D-SL or Fanuc 32iT with 15-inch screen

Chip conveyor as standard

Toolsetter as standard

Perfect free chip fall

Machining of bars or integrated automation with robotic system

Large panoramic window to the working area



Stable
Compact
Dynamic
Universal
Precise

Powerful tool drive
in the turret

Rigid SPINNER servo turret
with BMT45 or VDI25
toolholder

Real Y-axis

Rigid machine
base as a one-
piece casting

CNC tailstock
or subspindle

Modern
motorspindles with
52 mm or 65 mm
bores

Hardened and ground sliding
guideways for best vibration
damping

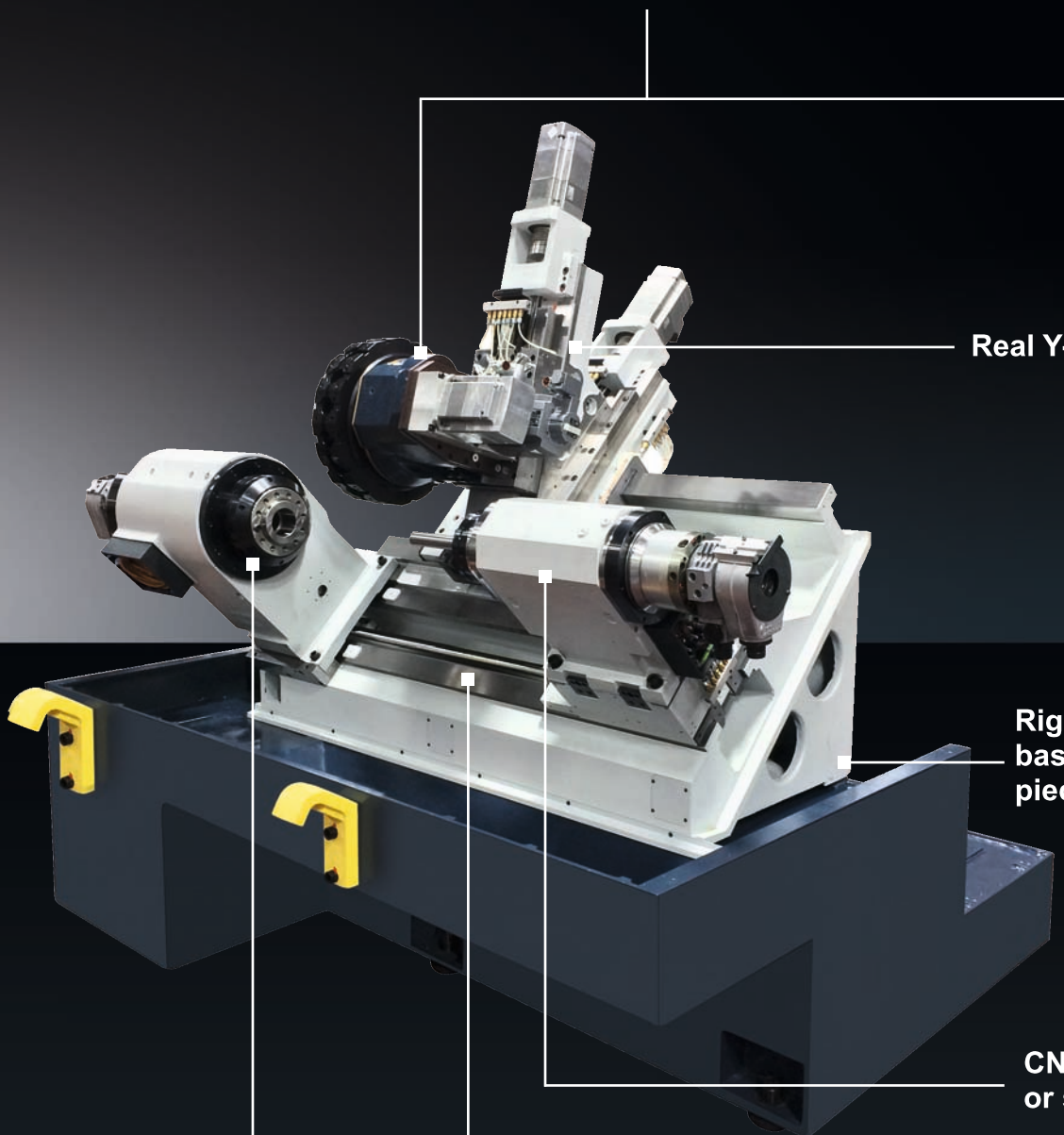

- Rigid SPINNER-turret with high milling performance that can work on both spindles
- Up to 16 tool stations

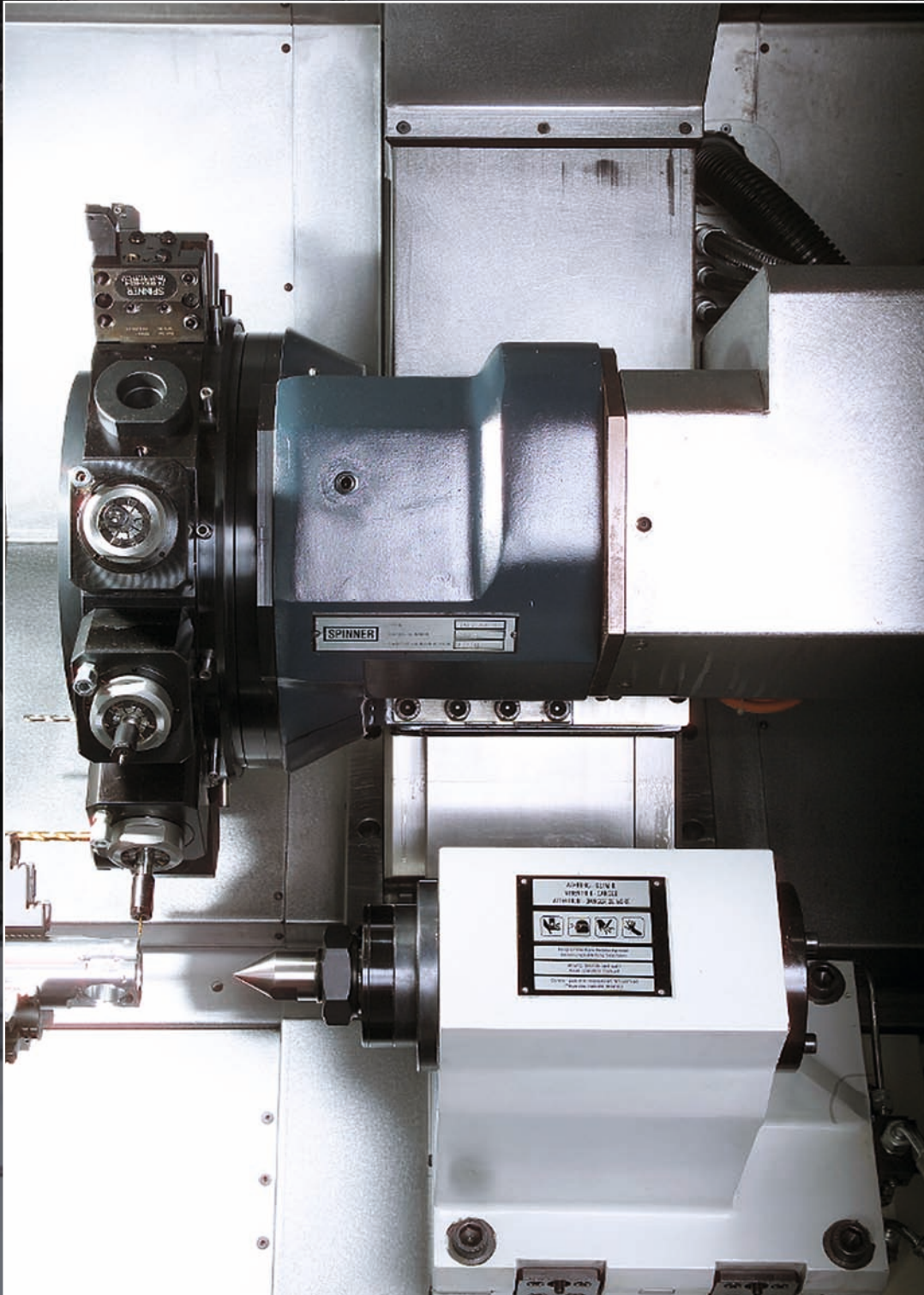
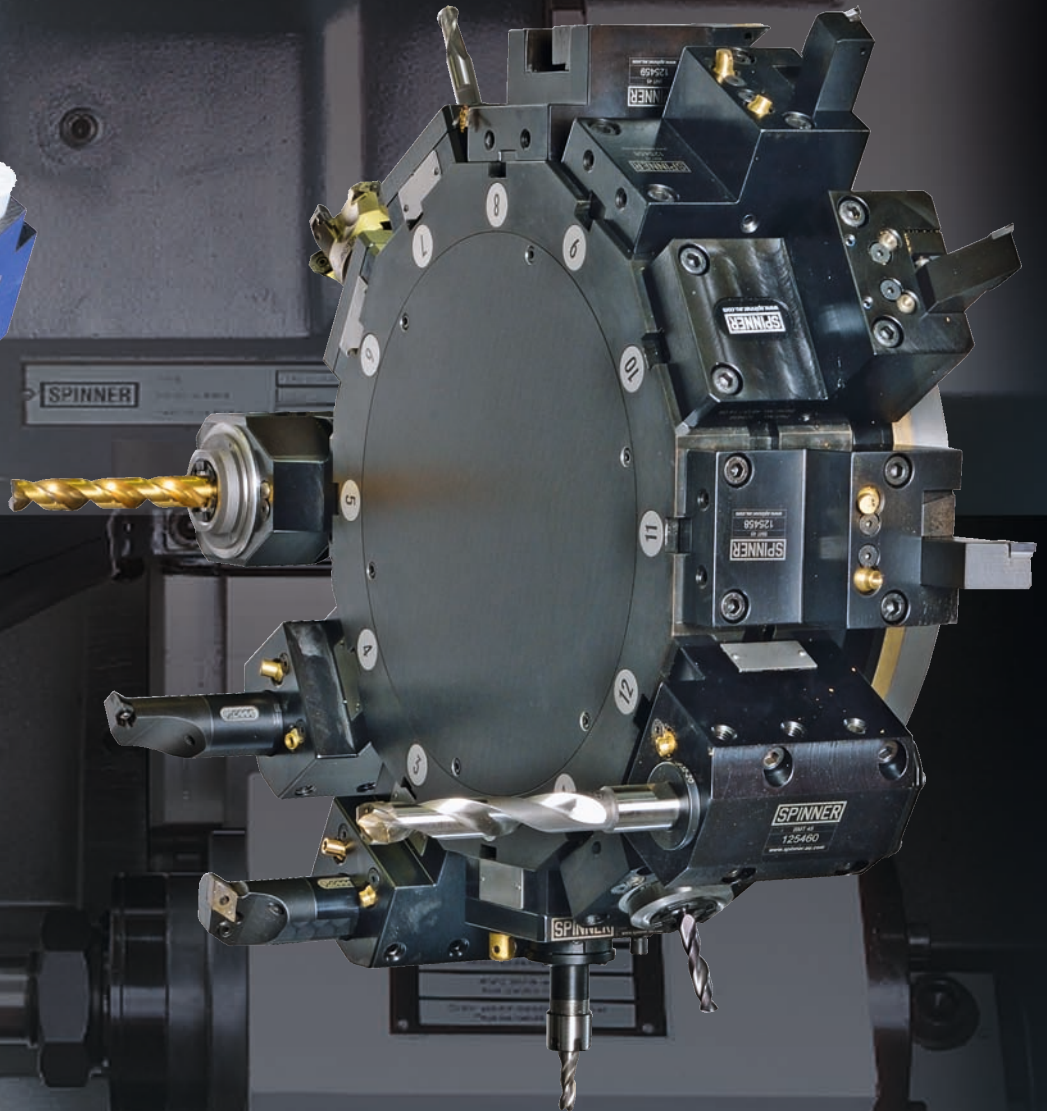

Figure shows turret disc VDI25 and CNC tailstock

•Tool holder BMT45

Your advantages at one glance when using BMT45 tool holders

- ✔ High toolholder exchange precision
- ✔ No adjustment is required
- ✔ High stiffness
- ✔ Higher turning and milling performance



•Or toolholder VDI25

Automation solutions

Fully automated production solutions for large-scale production
FROM A SINGLE SOURCE from SPINNER and SPINNER-
Automation



Your advantages at one glance

- Increase in productivity
- Cost reduction
- Optimal processes for your machining requirements
- Everything from one source

Ask us for your solution!

Bar feeding system

SPINNER Bar feeding magazines

For feeding bars up to a maximum of 3200mm



Part catcher



For collection of cut-off parts to put them in a storage bin or to place them on a conveyor belt

Working area	TC300-52	TC300-65
Swing diameter	400 mm	400 mm
Max. turning diameter	~200 mm	~200 mm
Max. turning length	400 mm	400 mm
X1 / Z-axis	180 / 450 mm	180 / 450 mm
Y-axis (option)	+40 / -40 mm	+40 / -40 mm
Axes		
Rapide traverse X / Y / Z	15 / 15 / 24 m/min	15 / 15 / 24 m/min
Spindle 1		
Max. spindle speed	5.000 rpm	4.000 rpm (option 5.000 rpm)
Spindle nose	A6/DIN	A8/DIN
Chuck diameter	210 mm	250 mm
Spindle bore	52 mm	65 mm
Performance P_{max}	23,5 kW	34 kW
Torque M_{max}	150 Nm	325 Nm
Spindle 2		
Max. spindle speed	7.000 rpm	7.000 rpm
Spindle nose	Ø100 mm	Ø100 mm
Chuck diameter	165 mm	165 mm
Performance P_{max}	13,8 kW	13,8 kW
Torque M_{max}	189 Nm	189 Nm
Turret		
Number of tool stations	12/16 (VDI25) ; 12 (BMT45)	12/16 (VDI25) ; 12 (BMT45)
Number of driven tools (option)	all	all
Toolholder	VDI25 / BMT45	VDI25 / BMT45
Max. speed of driven tools	6.000 rpm	6.000 rpm
Performance P_{max}	16,5 kW	16,5 kW
Torque M_{max}	35 Nm	35 Nm
General indications		
Dimensions (L x W x H) ¹⁾	2230 x 1700 x 2165 mm	2430 x 1700 x 2165 mm
Weight ²⁾	~3.700 kg	~4.200 kg

1) See floorplan

2) Machine net weight SMCY

Main Spindle TC300-52 5.000 rpm

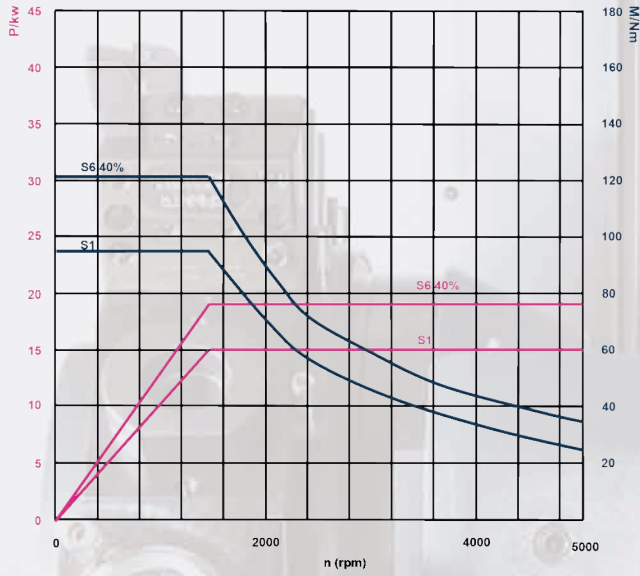

Main Spindle TC300-65 4.000 rpm

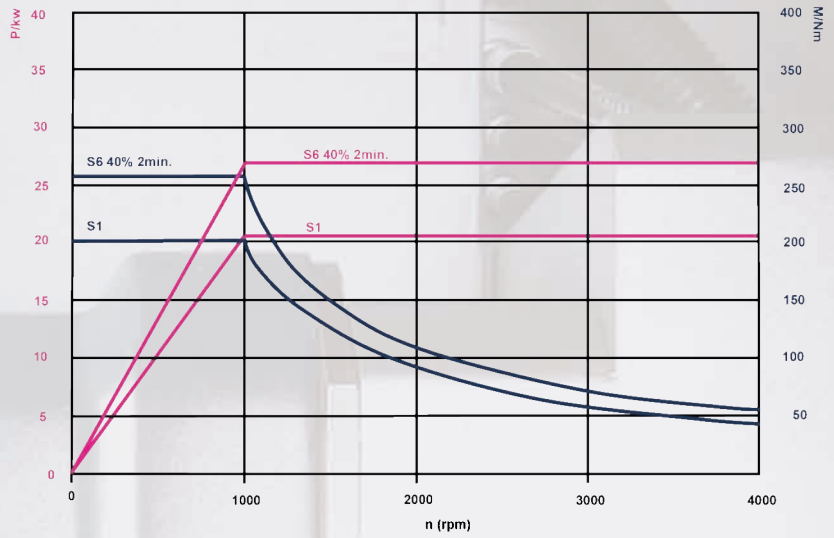

Sub Spindle TC300 7.000 rpm

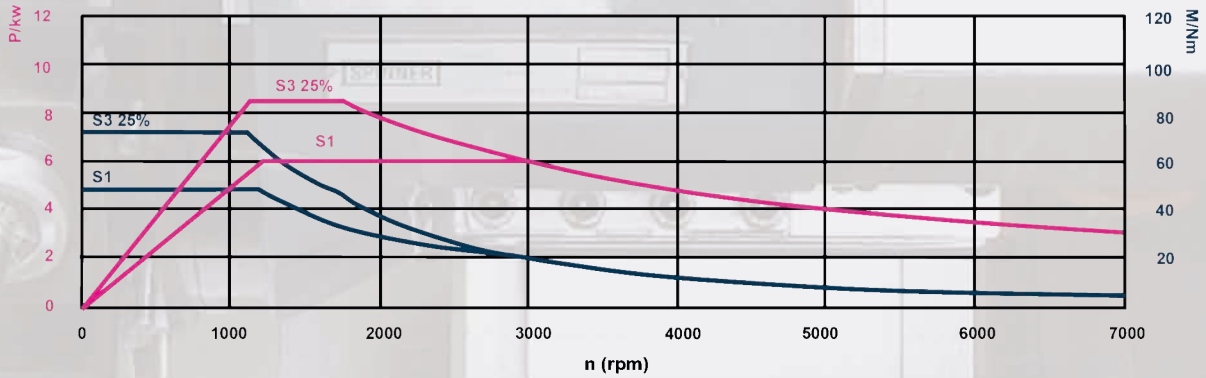

Driven Tool

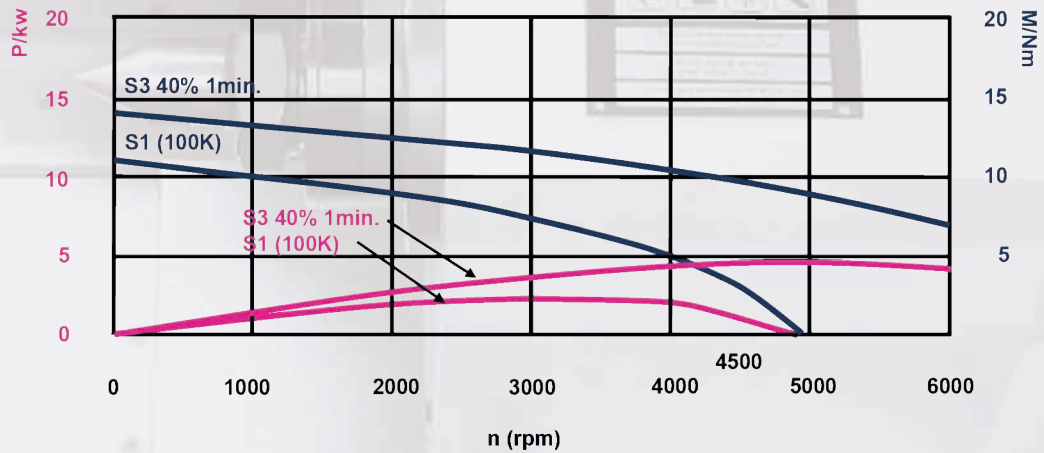

Air nozzle for compressed air on main spindle/sub spindle

Clamping force control by differential pressure for main spindle and/or sub spindle

Main spindle with spindle bore 65 mm (standard 52 mm)

- Turret disc VDI25 16-position (standard 12-position)
- Turret disc BMT45 12-position

- Toolholder package BMT45
- Toolholder package VDI25
- Hard turning package for superfinishing

- Component measurement by touch probe in turret

Suction unit for coolant mist
Fire extinguishing system

External tool measurement

Scraping type conveyor

High pressure coolant pump 15/50 bar for tools with internal coolant supply

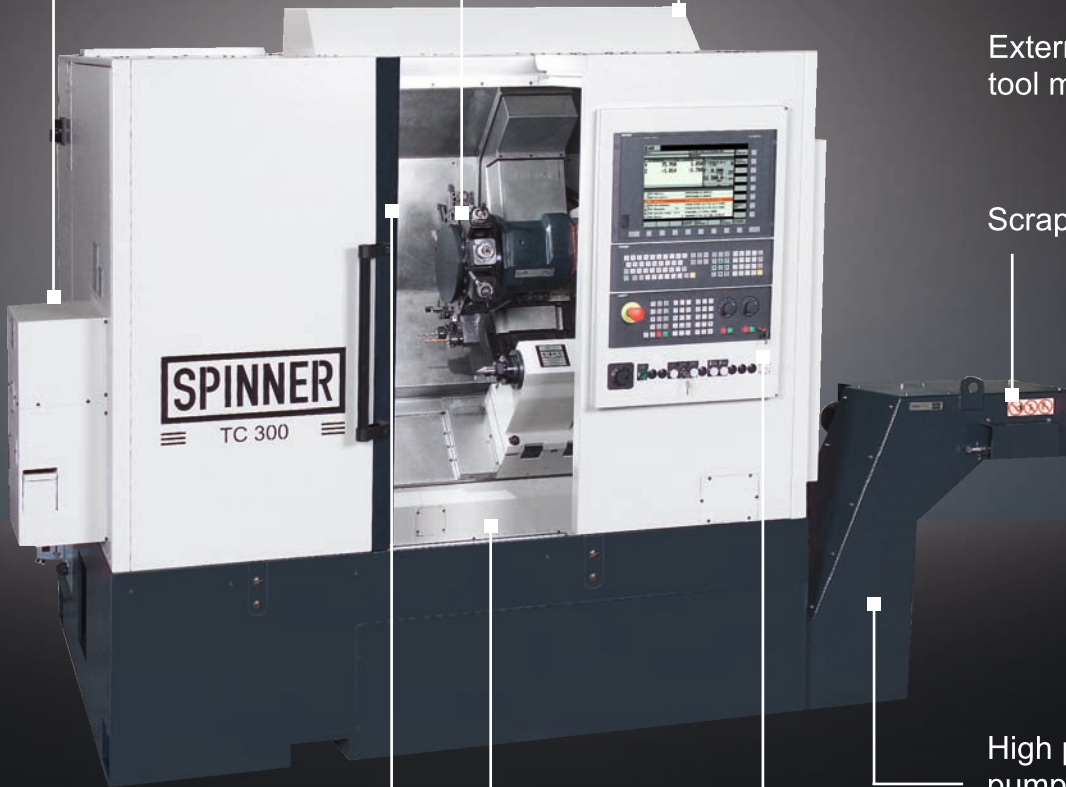

Bar feeder

Automatic door

Coolant pistol in the working area

Part catcher

Siemens 840D-SL
Fanuc 32iT with 15-inch screen

Clamping system for the workpiece

Glass scale X1-axis / Z1-axis

■ Also available with 2 turrets as model TTC300

Other options on demand

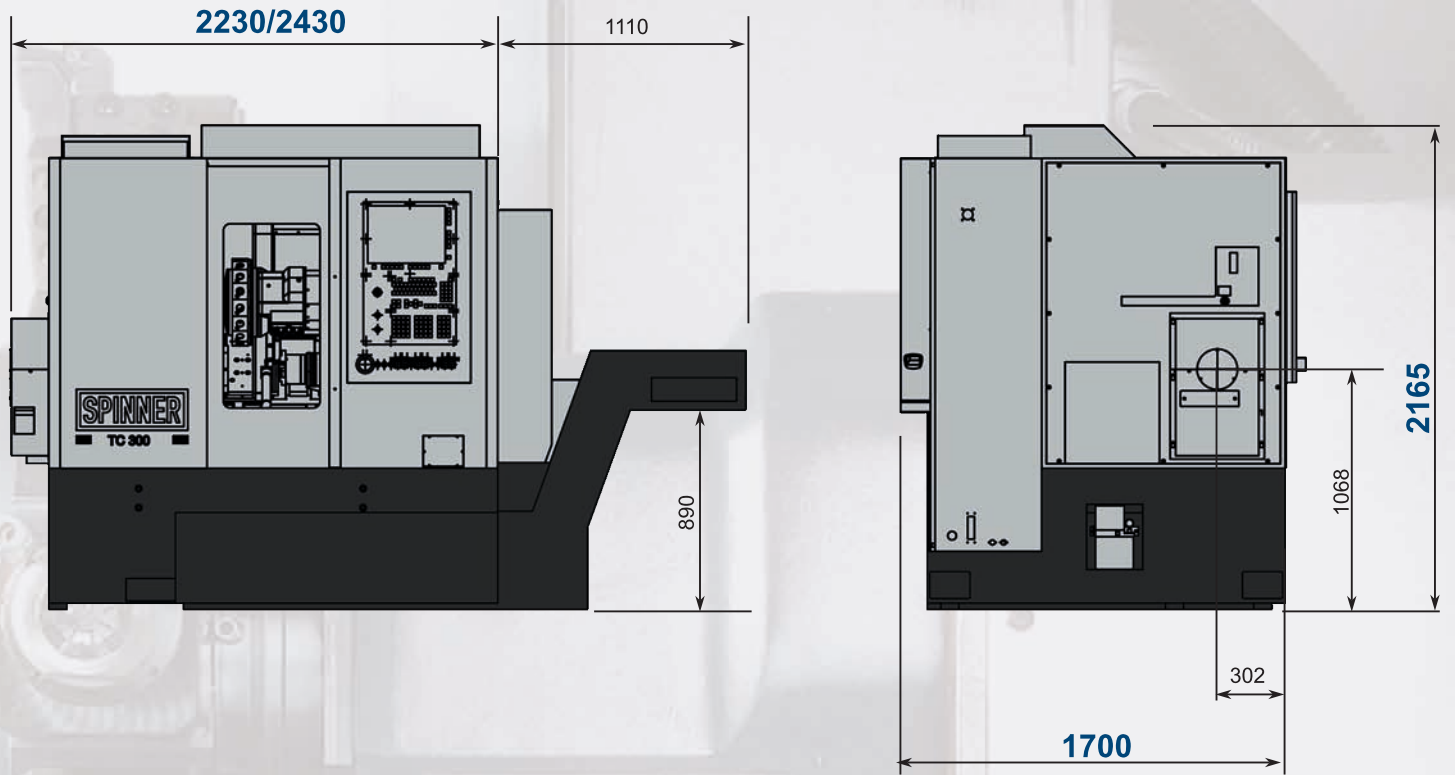

■ Version with standard chip conveyor

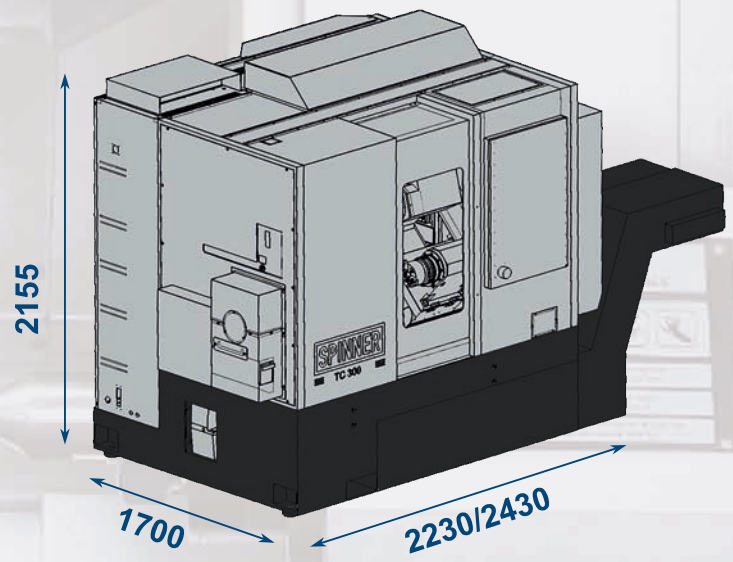

Compact dimensions for low space requirement



Werkzeugmaschinenfabrik GmbH



www.spinner.eu.com

Spinner Machine-Tools are working successfully world wide with many well known clients in more than 60 countries on 6 continents. We have been fortunate enough to attract small component suppliers in addition to well known global groups in all metal machining industries.

We have designed and produced the most modern machine-tools since 1950. More than 20.000 delivered machines demonstrate their high efficiency, precision and reliability, everyday.

Although Spinner is a medium-sized enterprise we produce and sell more than 1.000 CNC machines a year. And the number is increasing every year. Our company combines the know-how of a global player with the flexibility and cost-effective structures of a family owned business.

Place your trust in our products as well and let us know what we can do for you.



Video

SPINNER Werkzeugmaschinenfabrik GmbH

Rudolf-Diesel-Ring 24

82054 Sauerlach

Tel. +49 (0) 8104 803-0

Fax +49 (0) 8104 803-19

sales@spinner.eu.com



Version 29.4.2015

Technical changes of specifications and pictures are subject to change without notice - Pictures can include options, accessories