

SPINNER

TC400

Precise Universal Lathe

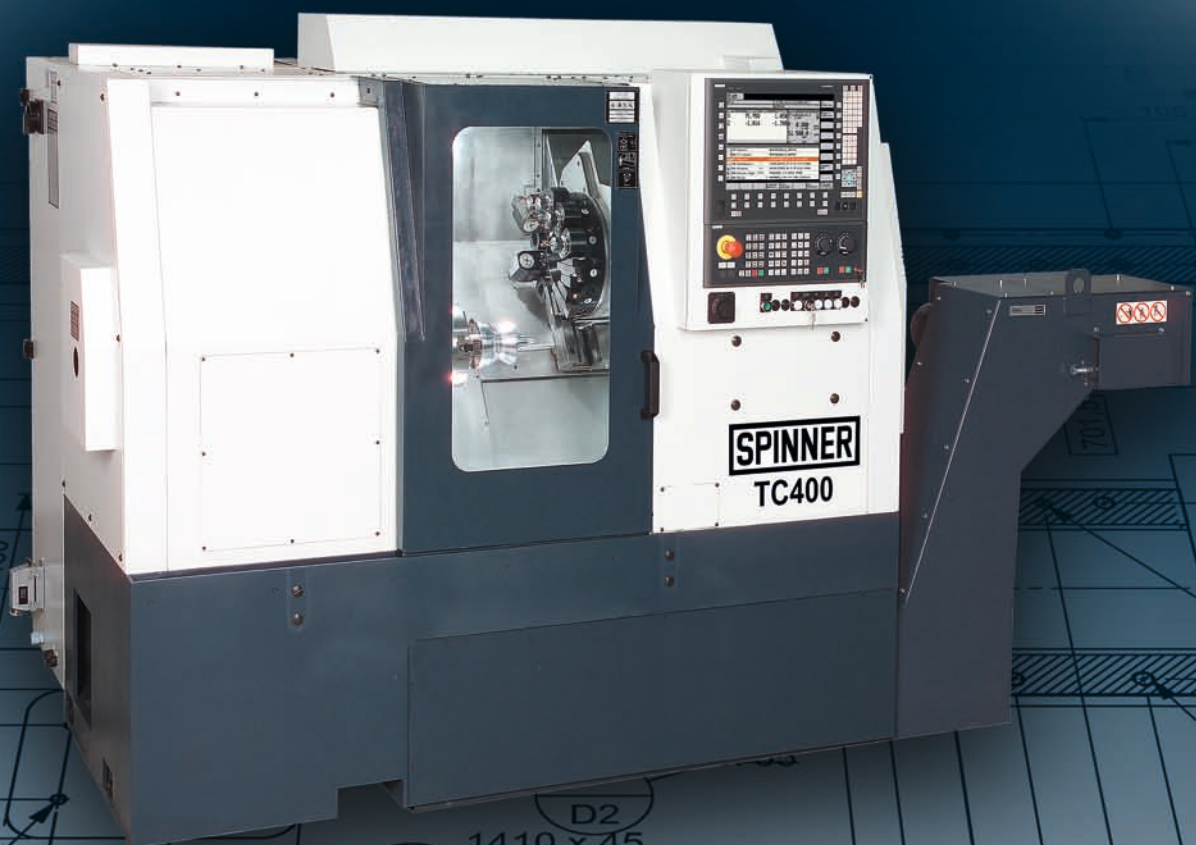

Mechanical Engineering
Made in Europe

www.spinner.eu.com
sales@spinner.eu.com

Machine Highlights

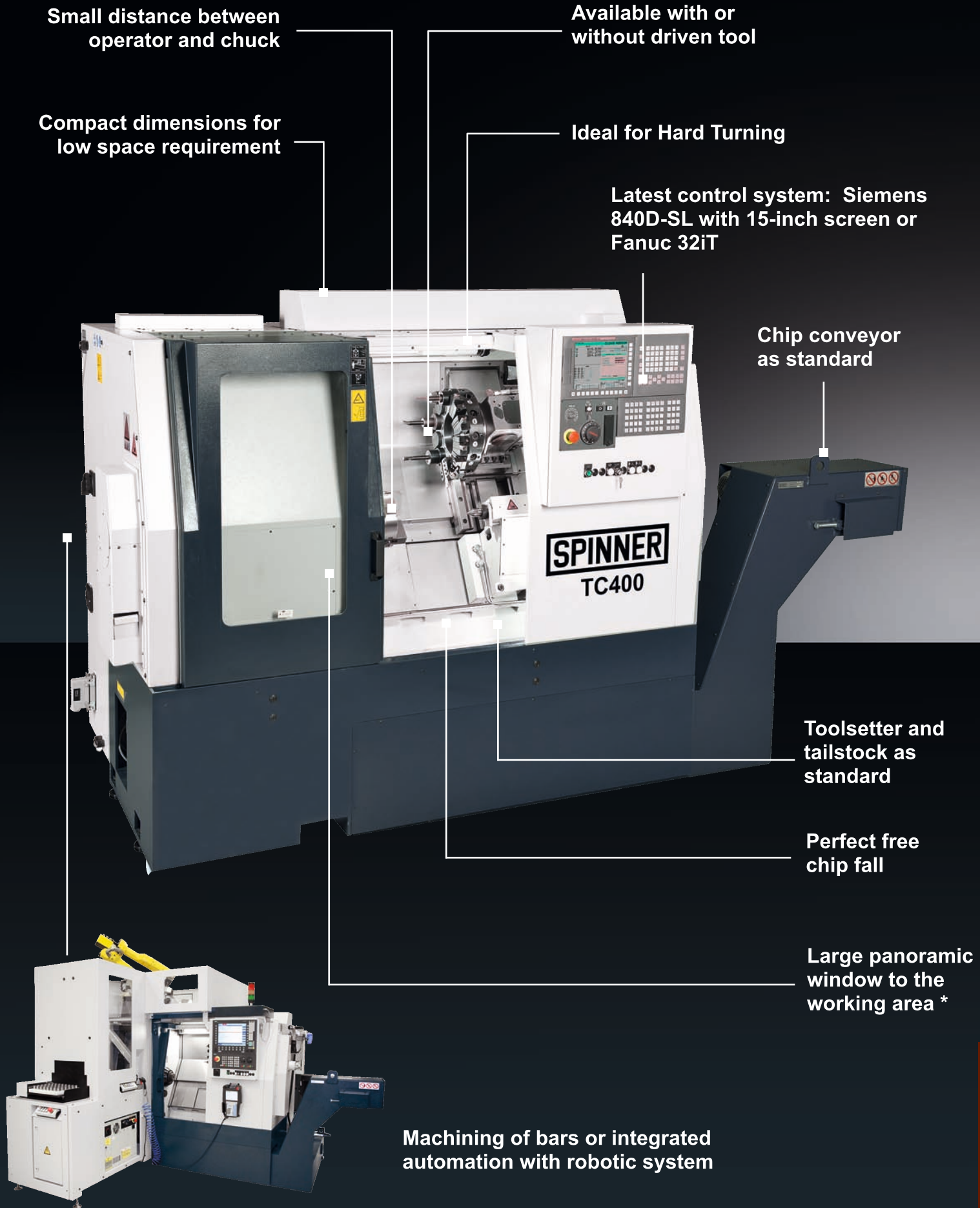

Small distance between operator and chuck

Available with or without driven tool

Compact dimensions for low space requirement

Ideal for Hard Turning

Latest control system: Siemens 840D-SL with 15-inch screen or Fanuc 32iT

Chip conveyor as standard

SPINNER
TC400

Toolsetter and tailstock as standard

Perfect free chip fall

Large panoramic window to the working area *

Machining of bars or integrated automation with robotic system

Stable
Compact
Dynamic
Universal
Precise

Up to 12 driven tools

Servo turret with
toolholder VDI30

Modern motorspindles
with 52 mm bore
(optional 42 mm)

Rigid machine
base as a one-
piece casting

Hardened and ground sliding
guideways for best vibration
damping

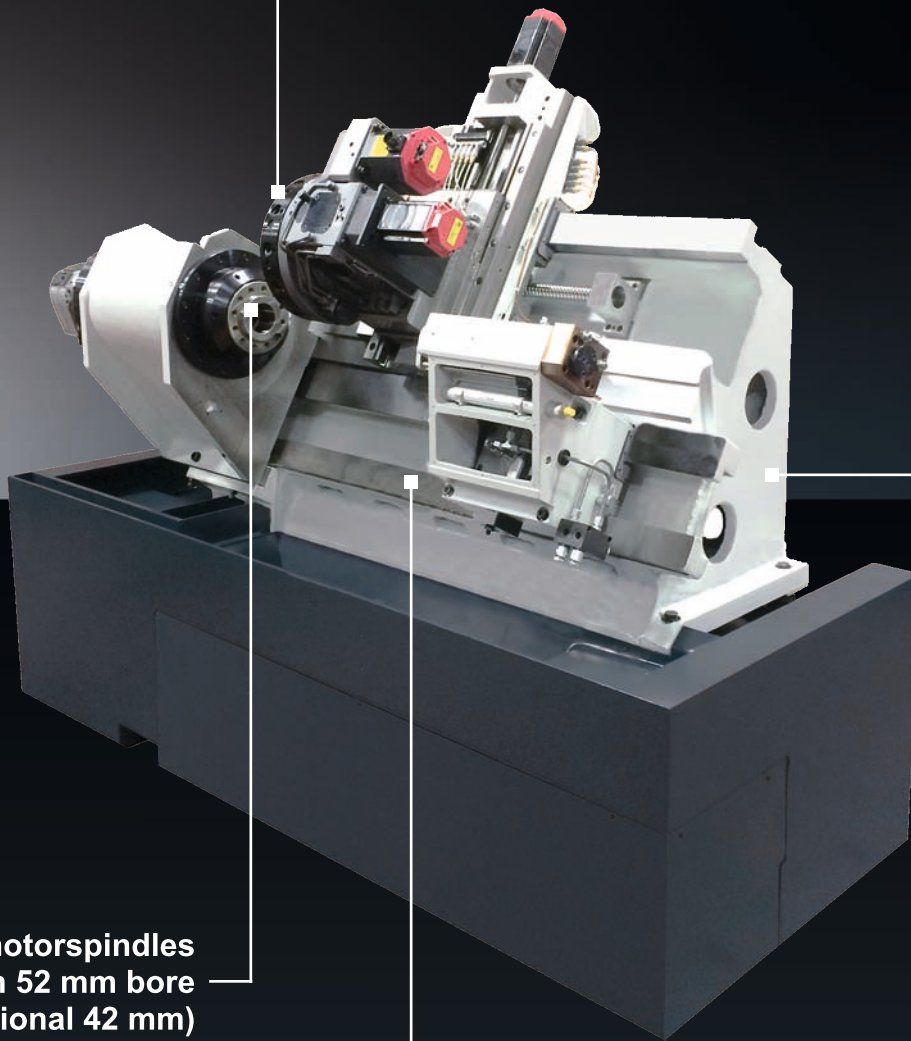

Automation solutions

Fully automated production solutions for large-scale production
FROM A SINGLE SOURCE from SPINNER and SPINNER-
Automation

Robots



Your advantages at one glance

- Increase in productivity
- Cost reduction
- Optimal processes for your machining requirements
- Everything from one source

Bar feeding system and Part catcher



* Part catcher can not be combined with panoramic window

SPINNER Bar feeding magazines for short bars or 3-meters-magazines
All "from a single source"

Ask us for your solution!

Working area	TC400-52	TC400-42 (option)
Swing diameter	400 mm	
Max. turning diameter	~280 mm	
Max. turning length	~500 mm	
X / Z-axis	200 / 515 mm	
Axes		
Rapide traverse X / Z	15 / 24 m/min	
Spindle 1		
Max. spindle speed	5.000 rpm	6.000 rpm
Spindle nose	A6/DIN	Ø 110 mm
Chuck diameter	210 mm	140 mm
Spindle bore	52 mm	42 mm
Performance P_{max}	23,5 kW	15 kW
Torque M_{max}	150 Nm	96 Nm
Turret		
Number of tool stations	12 (VDI30)	
Number of driven tools (option)	all	
Toolholder	VDI30	
Max. speed of driven tools	up to 4.500 rpm	
Performance P_{max}	16,5 kW	
Torque M_{max}	35 Nm	
General indications		
Dimensions (L x W x H) ¹⁾	2195 x 1350 x 1865 mm	
Weight ²⁾	~3.000 kg	~3.000 kg

1) See floorplan; 2) Machine net weight MC

Torque and performance diagrams

Main spindle TC400-42 6.000 rpm

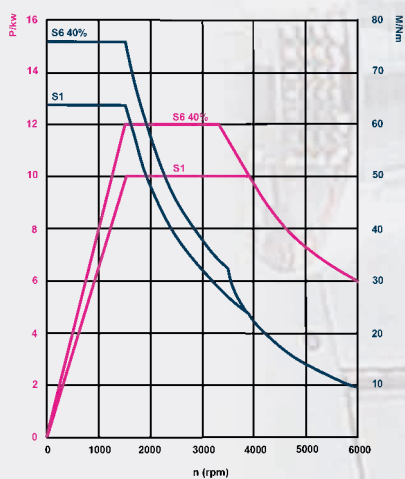

Main spindle TC400-52 5.000 rpm

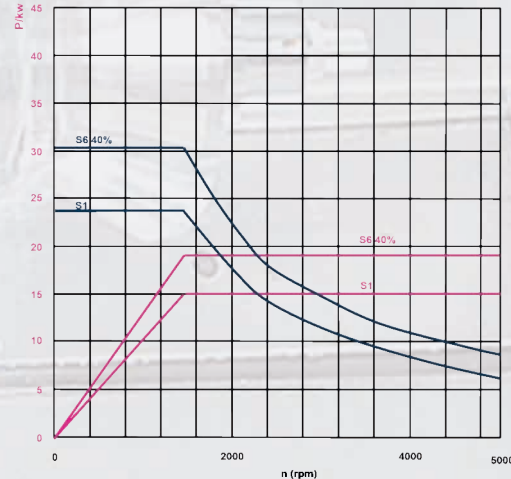

Driven tool

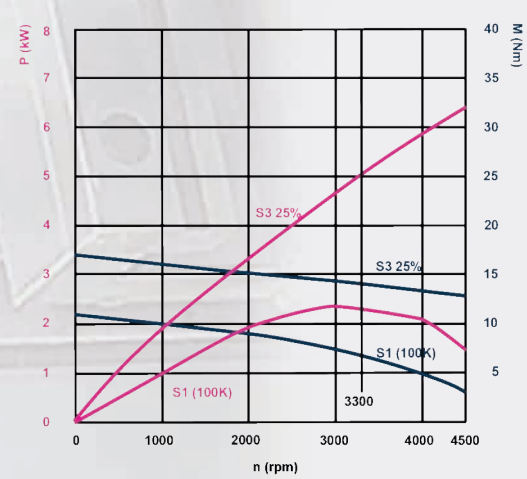

- Toolholder package VDI30
- Hard turning package for superfinishing
- Component measurement by touch probe in turret

Sensitive clamping force control by differential pressure for main spindle

Suction unit for coolant mist
Fire extinguishing system

External tool measurement

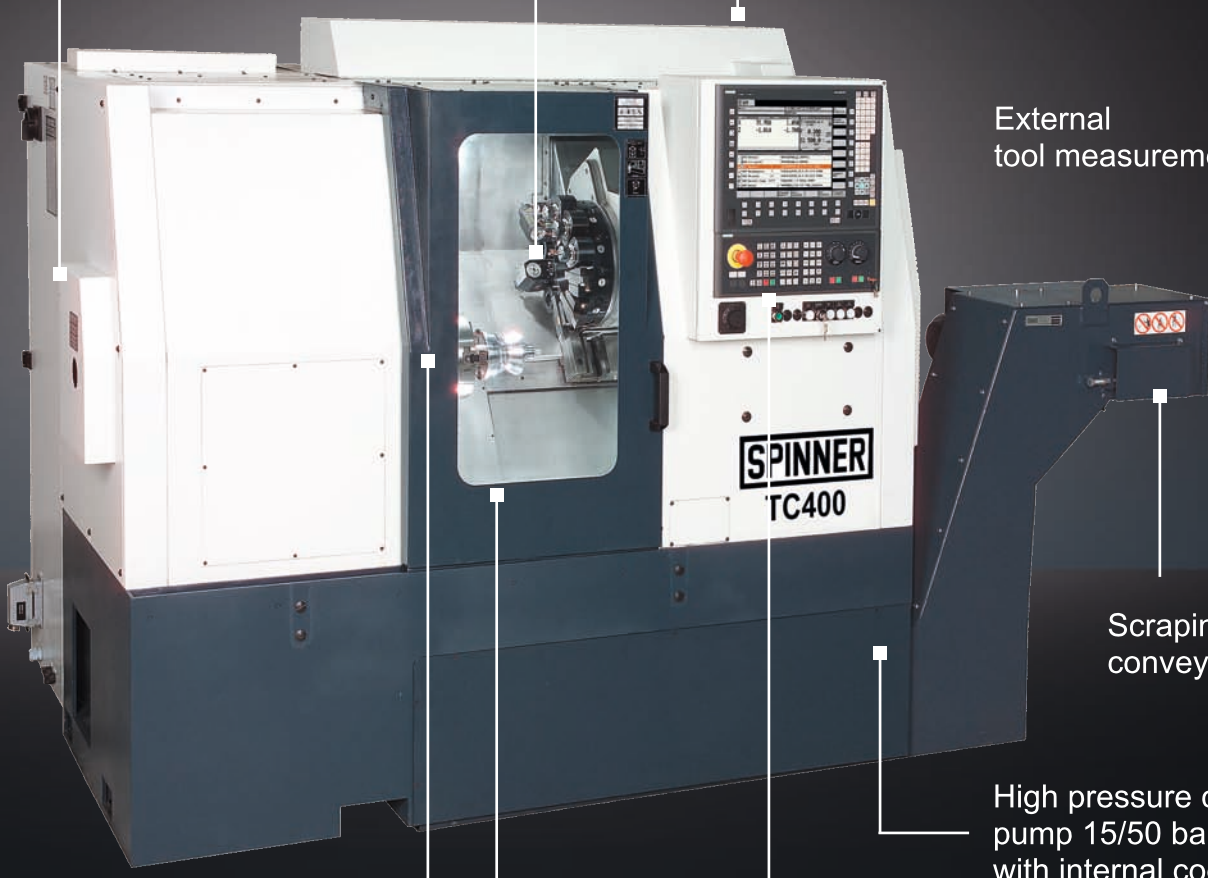

Bar feeder

Automatic door

High pressure coolant pump 15/50 bar for tools with internal coolant supply

Scraping type conveyor

Siemens 840D-SL with 15-inch screen
Fanuc 32iT

Coolant pistol in the working area

Steady rest

Part catcher

Clamping system for the workpiece

Spindle bore with 42 mm

Glass scale X-axis / Z-axis

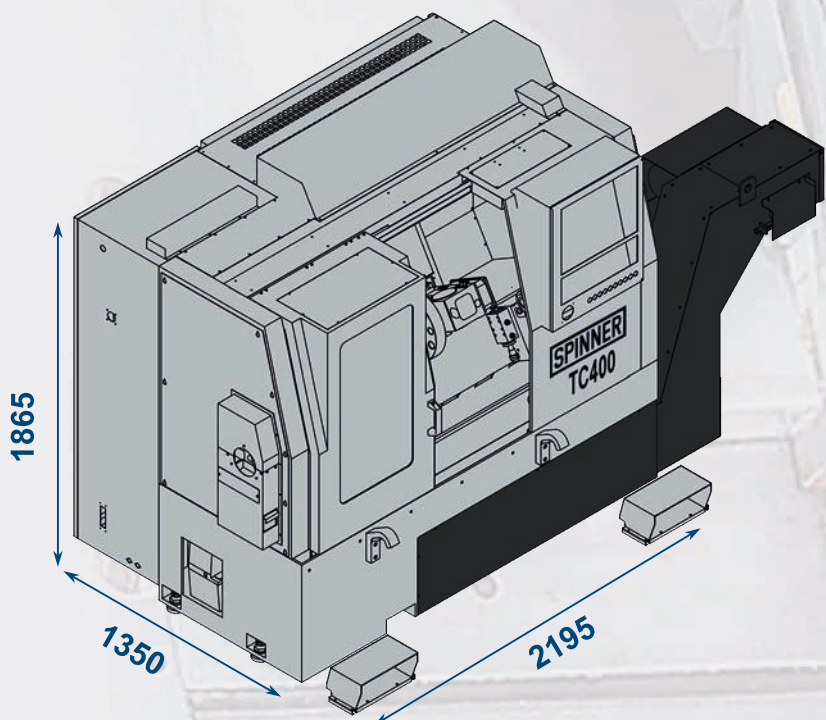
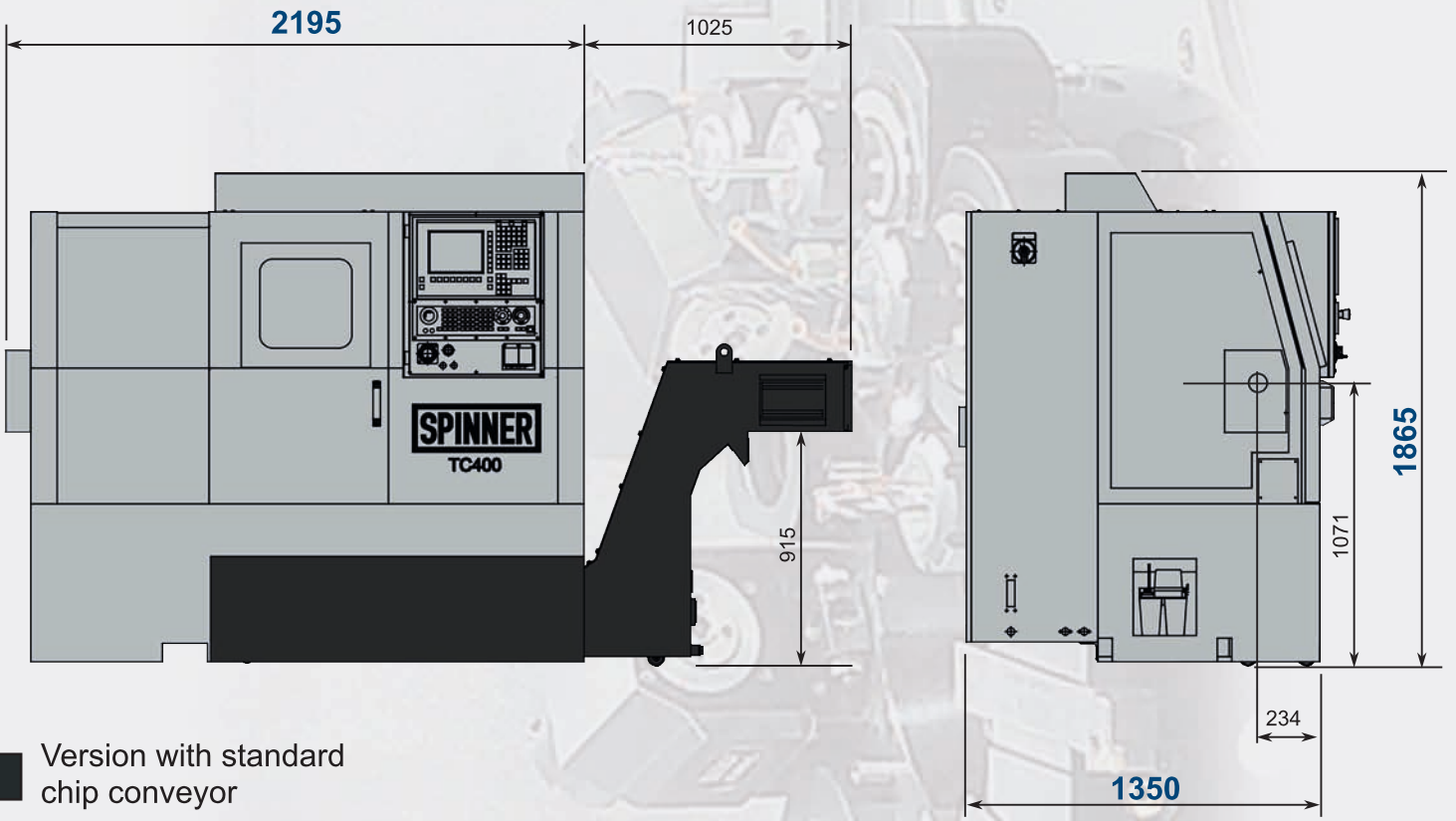

Compact dimensions for low space requirement



Werkzeugmaschinenfabrik GmbH



Spinner Machine-Tools are working successfully world wide with many well known clients in more than 60 countries on 6 continents. We have been fortunate enough to attract small component suppliers in addition to well known global groups in all metal machining industries.

We have designed and produced the most modern machine-tools since 1950. More than 20.000 delivered machines demonstrate their high efficiency, precision and reliability, everyday.

Although Spinner is a medium-sized enterprise we produce and sell more than 1.000 CNC machines a year. And the number is increasing every year. Our company combines the know-how of a global player with the flexibility and cost-effective structures of a family owned business.

Place your trust in our products as well and let us know what we can do for you.



Video

SPINNER Werkzeugmaschinenfabrik GmbH

Rudolf-Diesel-Ring 24

82054 Sauerlach

Tel. +49 (0) 8104 803-0

Fax +49 (0) 8104 803-19

sales@spinner.eu.com



Version 27.5.2015

Technical changes of specifications and pictures are subject to change without notice - Pictures can include options, accessories